

Piston Cooling Jets on Cummins B Series Diesel Engines

The AERA Technical Committee offers the following information regarding the use of piston cooling jets on Cummins B Series diesel engines. Cummins uses three different designs of piston cooling jets for these engines. These engines have been manufactured in many different locations and the design usage is not specific to the manufacture location.

A brief description of the two unique designs follows:

1. **J-Jet Cooling Nozzle:** Two different designs which locate and bolt on, see Figure 1.
2. **Saddle Jet Cooling Nozzle:** Locates through a drilled passage in the crankshaft main housing bore, as shown below in Figure 2.

The two styles of J-jet nozzles are shown below and individual parts are not interchangeable.

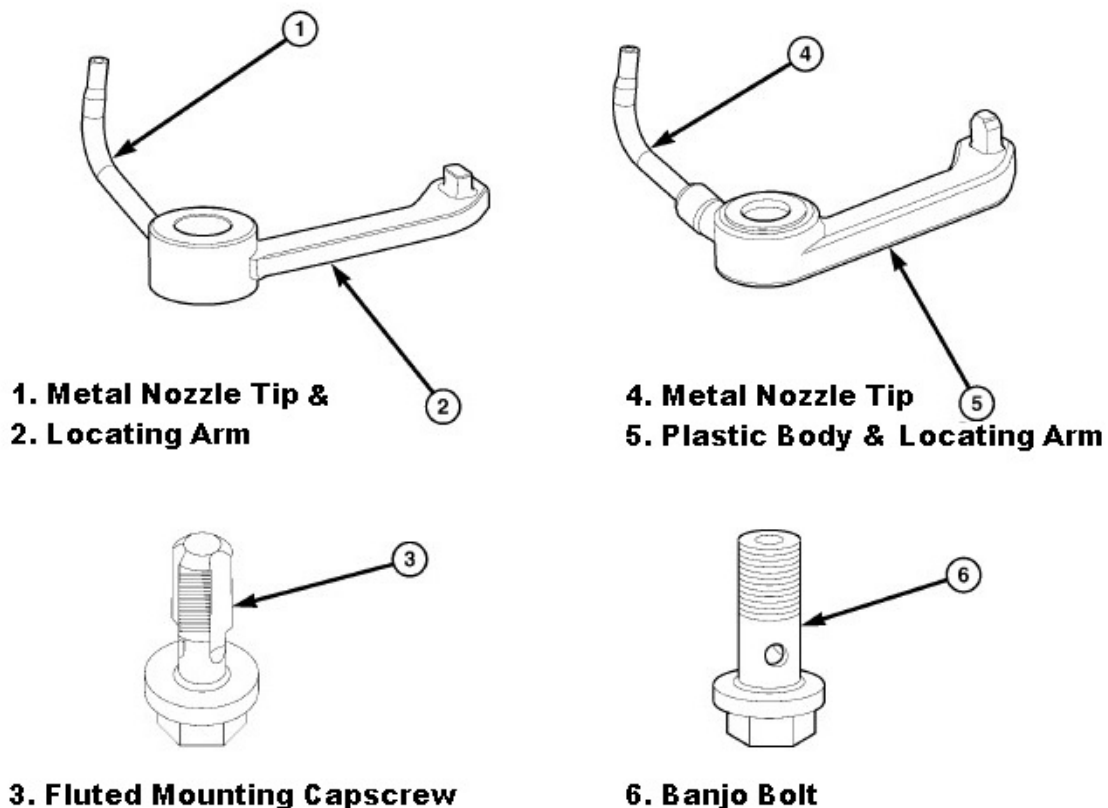

Figure 1. J-Jet Piston Cooling Nozzles

NOTE: Blocks using J- jet piston cooling nozzles may be machined for saddle jet piston cooling nozzles as well. If this is the case, plugs will be installed in the saddle jet piston cooling nozzle locations. Some engine builders prefer the saddle jet design for the simplistic nature with fewer components involved.



Figure 2. Saddle Jet Piston Cooling Nozzle