



Piston to Rod Assembly on 1999-2008 Ford 4.6L VIN W Engines

The AERA Technical Committee offers the following information on piston to rod assembly for 1999-2008 Ford 4.6L, VIN W engines. This information should be referenced anytime the pistons and rods are being serviced during engine rebuild.

The correct piston to rod assembly orientation is essential when building an engine and therefore rods and pistons should always be marked for reference during assembly. In some engines orientation is not critical, but it is a good practice to mark all assemblies before disassembly.

Ford uses two methods of assembly for this engine, a full floating pin and a press fit pin. Service information for the press fit pin indicates the connecting rod may be mounted to the piston in either direction. For full floating pistons, the rod markings should match the piston front markings when assembled as shown in Figure 1 below.

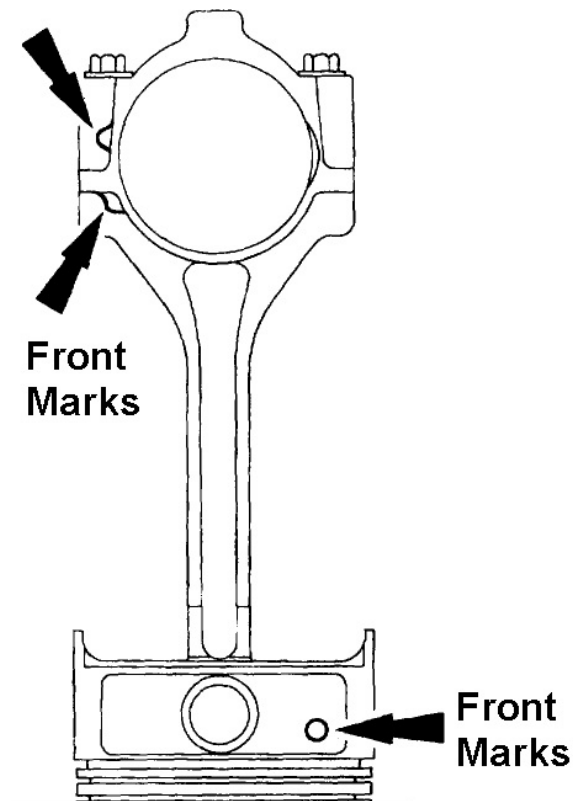

Figure 1. Full Floating Piston Pin Design