

## Injector Sleeve Installation on John Deere 6090 Diesel Engines

The AERA Technical Committee offers information on the installation of injector sleeves for John Deere 6090 diesel engines. This repair is done after the cylinder head has been removed from the engine block and the head is placed on a sturdy workbench.

Follow the procedure listed below after obtaining the new injector sleeves and special tool JDG1649A. Do not remove or mix sleeve O-Rings. Service sleeve is provided with O-Rings installed on it. The upper O ring is diesel fuel compatible while the lower one is coolant compatible. Both O-Rings are identified by a different color and are not available as spare parts from John Deere.

1. Support cylinder head so that the lower surface of the head is approximately 50 mm (2.0 in.) above workbench.
2. Apply LOCTITE® 620 (TY15941) completely around the lower, outer edge of the fuel injection nozzle sleeve (C).
3. Do not use any petroleum based products to lubricate fuel injector sleeve O-Rings or the O-Rings will swell excessively.
4. Lubricate the new O-Rings with liquid soap.
5. Set fuel injection nozzle sleeve (C) over bore and place JDG1649A Injector Sleeve Installer (E) into the sleeve.
6. Using a hammer, strike the nozzle installation tool carefully to drive the sleeve fully into the bore.

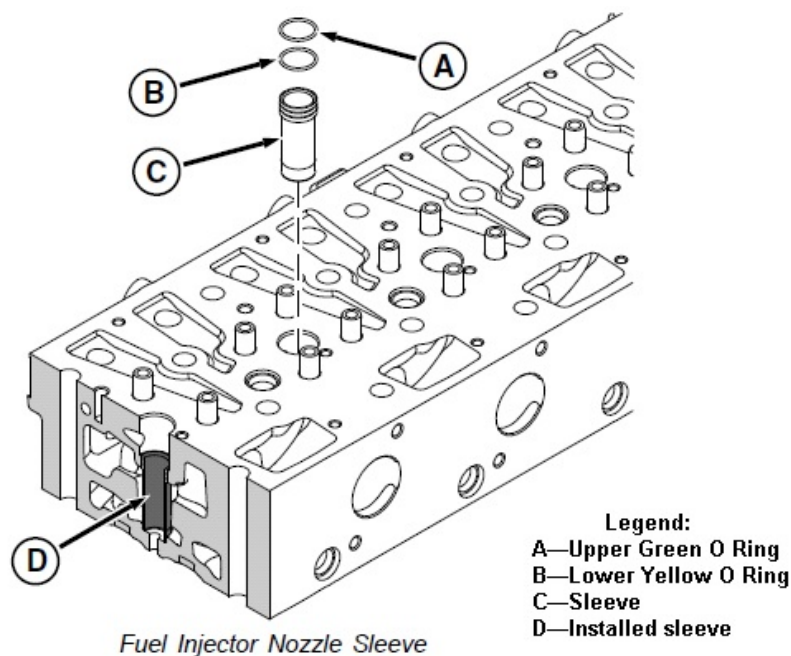

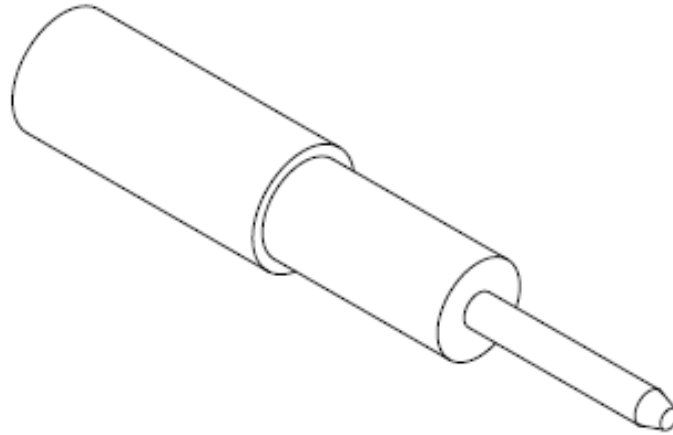

*JDG1649A Injector Sleeve Installation Tool*